

# RAK833 LoRa Gateway

## Mini PCIe modules with SPI and USB interface Datasheet V1.2

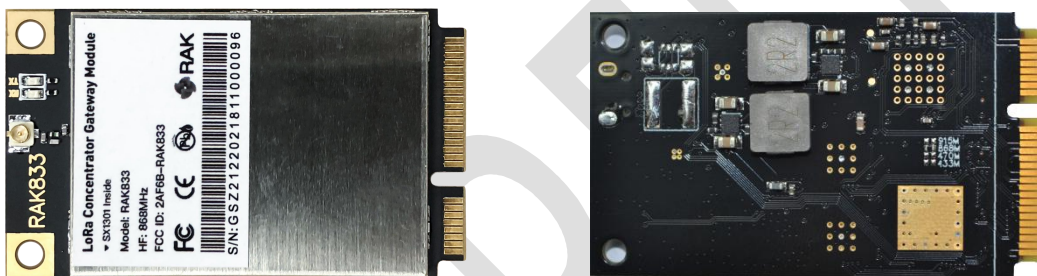

### Abstract

Technical data sheet describing RAK833 series LoRa gateway modules. The modules are a complete and cost efficient LoRa gateway solution offering up to 10 programmable parallel demodulation paths. It targeted at smart metering fixed networks and Internet of Things applications with up to 5000 nodes per km<sup>2</sup> in moderately interfered environment. . The modules have the industry standard PCI Express Mini Card form factor, which enables easy integration into an application board and is also ideal for manufacturing of small series.

© 2017 Rakwireless all rights reserved .

Mentioned in this document , the actual company and product names, trademarks are their respective owners.

After update the new version, this document without prior notice.

# Contents

## Contents

<b>Contents.....</b>	<b>2</b>
<b>1. Functional description.....</b>	<b>4</b>
<b>1.1. Overview.....</b>	<b>4</b>
<b>1.2. Product features.....</b>	<b>4</b>
<b>1.3. Block diagram.....</b>	<b>4</b>
<b>1.4. Product description.....</b>	<b>5</b>
<b>1.5. Supported features.....</b>	<b>5</b>
<b>2. Interfaces.....</b>	<b>5</b>
<b>2.1. Module supply input.....</b>	<b>5</b>
<b>2.2. Antenna RF interfaces.....</b>	<b>5</b>
<b>2.3. SPI interface.....</b>	<b>5</b>
<b>2.4. USB interface.....</b>	<b>6</b>
<b>2.5. RESET.....</b>	<b>6</b>
<b>2.6. SPDT_SEL.....</b>	<b>6</b>
<b>2.7. GPS_PPS.....</b>	<b>6</b>
<b>3. Pin definition.....</b>	<b>6</b>
<b>3.1. Pin assignment.....</b>	<b>6</b>
<b>4. Electrical specifications.....</b>	<b>9</b>
<b>4.1. Absolute maximum rating.....</b>	<b>9</b>
4.1.1. Maximum ESD.....	9
<b>4.2. Operating conditions.....</b>	<b>10</b>
4.2.1. Operating temperature range.....	10
4.2.2. Supply/power pins.....	10
4.2.3. Current consumption.....	10
4.2.4. LoRa RF characteristics.....	10

<b>5. Mechanical specifications.....</b>	<b>11</b>
<b>6. Inner schematic.....</b>	<b>12</b>
<b>7. Reference application.....</b>	<b>15</b>
<b>8. Contact information.....</b>	<b>16</b>
<b>9. Change Note.....</b>	<b>16</b>

RAK WIRELESS

# 1. Functional description

## 1.1. Overview

The RAK833 series comprises complete and cost efficient LoRa gateway modules in the industry standard PCI Express Mini Card form factor, which enables an easy integration into an application board and it is also ideal for manufacturing of small series.

RAK833 modules support 470-510MHz for China, 868MHz for Europe, 915MHz for North America over different regions.

RAK833 modules support up to -142 dBm sensitivity with SX1255/7 Tx/Rx front-end and max 27dBm TX power.

Typical applications are Smart Metering , Security Sensors Network, Agricultural Monitoring, Internet of Things (IoT) .

## 1.2. Product features

Module	Frequency	SPI	USB				
RAK833-00	433MHz	YES	YES				
RAK833-01	470MHz	YES	YES				
RAK833-10	868MHz	YES	YES				
RAK833-11	915MHz	YES	YES				

Table 1: RAK833 series main features summary

## 1.3. Block diagram

### Block Diagram

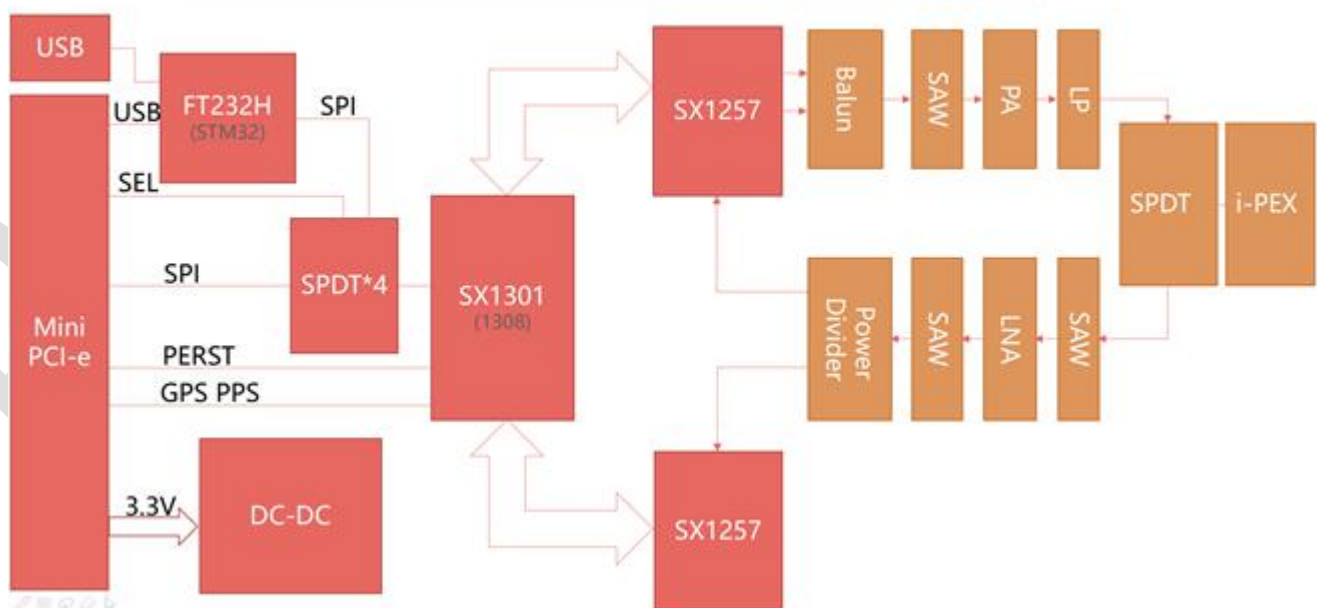

Figure 1: RAK833 series block diagram

As described Figure 1, each RAK833 series module integrates one SX1301 chip and two SX1255/7 and other chip for RF signal, which represents the core of the device, providing the related LoRa modem and processing functionalities. Additional signal conditioning circuitry is implemented for PCI Express Mini Card compliance, and one U.FL connectors are available for easy antennas integration.

## 1.4. Product description

RAK833 series modules provide LoRa gateway multi-mode technology:

- RAK833 is mainly designed for operation in China.
- RAK833 is mainly designed for operation in Europe and other countries.
- RAK833 is mainly designed for operation in America south-east Asia.

## 1.5. Supported features

Table 2 lists some of the main features supported by RAK833 series modules.

Feature	Description
TRX Indication	Module has two on board LEDs to indication the status of TX or RX, the LEDs are controlled by PA_EN and LNA_EN respectively.
Multichannel	10 programmable parallel demodulation paths, up to 8 RX channel and 1 TX channel for 125K LoRa.
SPI Interface	The SPI interface gives access to the configuration register of SX1301 via a synchronous full-duplex protocol.
USB2.0 Interface	Module build in FT2232H to convert SPI interface of SX1301 to USB2.0, which compatible with 3G/LTE card of mini-PCIe type.

Table 2: Some of the main features supported by RAK833 series modules

## 2. Interfaces

### 2.1. Module supply input

RAK833 series modules must be supplied through the 3.3Vaux pins by a DC power supply. The voltage must be stable, because during this operation the current drawn from 3.3Vaux can vary significantly, based on the power consumption profile of the SX1301 chip (see SX1301 DS).

### 2.2. Antenna RF interfaces

The modules have one RF interfaces over a standard U.FL connectors (Hirose U.FL-R-SMT) with a characteristic impedance of 50. The RF port (ANT1) supports both Tx and Rx, providing the antenna interface.

### 2.3. SPI interface

A SPI interface is provided on the PCIe\_SCK, PCIe\_MISO, PCIe\_MOSI, PCIe\_CSN pins of the system connector. The SPI interface gives access to the configuration register of SX1301 via a

synchronous full-duplex protocol. Only the slave side is implemented.

## 2.4. USB interface

RAK833 series modules can support high speed USB to SPI by FT2232H, it include a high-speed USB 2.0 compliant interface with maximum 480 Mb/s data rate, representing the interface for any communication with an external host application processor. The module itself acts as a USB device and can be connected to any USB host equipped with compatible drivers. For more information please refer to the data sheet of FT2232H.

## 2.5. RESET

RAK833 series includes the RESET active-high input signal to reset the radio operations as specified by the SX1301 Specification.

## 2.6. SPDT\_SEL

RAK833 series includes the SPDT\_SEL input for selecting SPI or USB interface. SPDT\_SEL="H", USB Port Enable, SPDT\_SEL="L", SPI Port Enable. Internal Pull UP, Default USB Port.

## 2.7. GPS\_PPS

RAK833 series includes the GPS\_PPS input for received packets time-stamped.

# 3. Pin definition

## 3.1. Pin assignment

No	PCI Express Mini Card E.M. Spec. Rev. 2.0	RAK833	Voltage domain	I/O	Description	Remarks
1	WAKE#	NC		N/A		Internally not connected
2	3.3Vaux	3.3Vaux	3.3Vaux	I	RAK833 supply input	Connect to external 3.3 V supply.
3	COEX1	NC		N/A		Internally not connected
4	GND	GND	GND	N/A	Ground	Internally not connected
5	COEX2	NC		N/A		Internally not connected
6	1.5V	NC		N/A		Internally not connected
7	CLKREQ#	NC		N/A		Internally not connected
8	UIM_PWR	NC		N/A		Internally not connected
9	GND	GND	GND	N/A	Ground	Connect to ground
10	UIM_DATA	NC		N/A		Internally not connected
11	REFCLK-	NC		N/A		Internally not connected
12	UIM_CLK	NC		N/A		Internally not connected

13	REFCLK+	NC		N/A		Internally not connected
14	UIM_RESET	NC		N/A		Internally not connected
15	GND	GND	GND	N/A	Ground	Connect to ground
16	UIM_SPU	NC		N/A		Internally not connected
17	UIM_IC_DM	SPDT_SEL		N/A		Internal 10k pull-up
18	GND	GND	GND	N/A	Ground	Connect to ground
19	UIM_IC_DP	GPS_PPS		N/A		Internally not connected
20	W_DISABLE1#	NC		N/A		Internally not connected
21	GND	GND	GND	N/A	Ground	Connect to ground
22	PERST#	RESET		I	RAK833 reset input	Active high for SX1301 reset.
23	PERn0	NC		N/A		Internally not connected
24	3.3Vaux	3.3Vaux	3.3Vaux	I	RAK833 supply input	Connect to external 3.3 V supply.
25	PERp0	NC		N/A		Internally not connected
26	GND	GND	GND	N/A	Ground	Connect to ground
27	GND	GND	GND	N/A		Connect to ground
28	1.5V	NC		N/A		Internally not connected
29	GND	GND	GND	N/A	Ground	Connect to ground
30	SMB_CLK	NC		N/A		Internally not connected

No	PCI Express Mini Card E.M. Spec. Rev. 2.0	RAK833	Voltage domain	I/O	Description	Remarks
31	PETn0	NC		N/A		Internally not connected
32	SMB_DATA	NC		N/A		Internally not connected
33	PETp0	NC		N/A		Internally not connected
34	GND	GND	GND	N/A	Ground	Connect to ground
35	GND	GND	GND	N/A	Ground	Connect to ground
36	USB_D-	USB_D-	USB	I/O	USB Data Line D-	90 nominal differential impedance. Pull-up, pull-down and series resistors as required by <i>USB 2.0 specifications</i> [6] are part of the USB pin driver and need not be provided externally.
37	GND	GND	GND	N/A	Ground	Connect to ground
38	USB_D+	USB_D+	USB	I/O	USB Data Line D+	90 nominal differential impedance. Pull-up, pull-down and series resistors as required by <i>USB 2.0 specifications</i> [6] are part of the USB pin driver and need not be provided externally.
39	3.3Vaux	3.3Vaux	3.3Vaux	I	RAK833I supply input	Connect to external 3.3 V supply. See 4.2.2 for detailed electrical specs.
40	GND	GND	GND	N/A	Ground	Connect to ground
41	3.3Vaux	3.3Vaux	3.3Vaux	I	RAK833 supply input	Connect to external 3.3 V supply.
42	LED_WWAN#	NC		N/A		Internally not connected
43	GND	GND	GND	N/A	Ground	Connect to ground
44	LED_WLAN#	NC		N/A		Internally not connected
45	Reserved	PCIe_SCK		I/O	Host SPI interface	Max 10MHz clock
46	LED_WPAN#	NC		N/A		Internally not connected
47	Reserved	PCIe_MISO		I/O	Host SPI interface	
48	1.5V	NC		N/A		Internally not connected
49	Reserved	PCIe_MOSI		I/O	Host SPI interface	
50	GND	GND	GND	N/A	Ground	Connect to ground
51	W_DISABLE2#	PCIe_CSN		I/O	Host SPI interface	
52	3.3Vaux	3.3Vaux	3.3Vaux	I	RAK833 supply input	Connect to external 3.3 V supply. See 4.2.2 for detailed electrical specs.

**Table 4: RAK833 series system connector pin assignment**



## 4. Electrical specifications



Stressing the device above one or more of the ratings listed in the Absolute Maximum Rating section may cause permanent damage. These are stress ratings only. Operating the module at these or at any conditions other than those specified in the Operating Conditions sections (chapter 4.1) of the specification should be avoided. Exposure to Absolute Maximum Rating conditions for extended periods may affect device reliability.



Operating condition ranges define those limits within which the functionality of the device is guaranteed.



Where application information is given, it is advisory only and does not form part of the specification.

### 4.1. Absolute maximum rating



Limiting values given below are in accordance with the Absolute Maximum Rating System (IEC 134).

Symbol	Description	Condition	Min.	Max.	Unit
3.3Vaux	Module supply voltage	Input DC voltage at 3.3Vaux pins	-0.3	3.6	V
USB	USB D+/D- pins	Input DC voltage at USB interface pins		3.6	V
SPDT_SEL	Port select	Input DC voltage at SPDT_SEL input pins	-0.3	3.6	V
RESET	RAK833 reset input	Input DC voltage at RESET input pin	-0.3	3.6	V
SPI	SPI interface	Input DC voltage at SPI interface pin	-0.3	3.6	V
GPS_PPS	GPS 1 pps input	Input DC voltage at GPS_PPS input pin	-0.3	3.6	V
Rho_ANT	Antenna ruggedness	Output RF load mismatch ruggedness at ANT1		10:1	VSWR
Tstg	Storage Temperature		-40	85	°C

Table 5: Absolute maximum ratings



The product is not protected against overvoltage or reversed voltages. If necessary, voltage spikes exceeding the power supply voltage specification, given in table above, must be limited to values within the specified boundaries by using appropriate protection devices.

#### 4.1.1. Maximum ESD

Parameter	Min	Typical	Max	Unit	Remarks
ESD sensitivity for all pins except ANT1			1000	V	Human Body Model according to JESD22-A114
ESD sensitivity for ANT1			1000	V	Human Body Model according to JESD22-A114
ESD immunity for ANT1			4000	V	Contact Discharge according to IEC 61000-4-2
			8000	V	Air Discharge according to IEC 61000-4-2

Table 6: Maximum ESD ratings



RAK833 modules are Electrostatic Sensitive Devices and require special precautions when handling. See section 7.2 for ESD handling instructions.

## 4.2. Operating conditions



Unless otherwise indicated, all operating condition specifications are at an ambient temperature of 25°C.



**Operation beyond the operating conditions is not recommended and extended exposure beyond them may affect device reliability.**

### 4.2.1. Operating temperature range

Parameter	Min.	Typical	Max.	Unit	Remarks
Normal operating temperature	-20	+25	+65	°C	Normal operating temperature range (fully functional and meet 3GPP specifications)
Extended operating temperature	-40		+85	°C	Extended operating temperature range (RF performance may be affected outside normal operating range, though module is fully functional)

Table 7: Environmental conditions

### 4.2.2. Supply/power pins

Symbol	Parameter	Min.	Typical	Max.	Unit
3.3Vaux	Module supply operating input voltage <sup>14</sup>	3.00	3.30	3.60	V

Table 8: Input characteristics of Supply/Power pins

<sup>14</sup> Input voltage at 3.3Vaux must be above the normal operating range minimum limit to switch-on the module.

### 4.2.3. Current consumption

Mode	Condition	Min	Typ	Max	Unit
Idle-Mode	All of the chip on the board enter idle mode or shutdown.	60	100		uA
Active-Mode (TX)	The power of TX channel is 23dBm and 3.3V supply.		TBD		mA
Active-Mode (RX)	TX disabled and shutdown PA.		TBD		mA

Table 9: Module 3.3Vaux supply current consumption

### 4.2.4. LoRa RF characteristics

The following table gives typically sensitivity level of the RAK833 :

Signal Bandwidth/[KHz]	Spreading Factor	Sensitivity/[dBm]
125	12	-137
125	7	-126
250	12	-136
250	7	-123
500	12	-134
500	7	-120

## 5. Mechanical specifications

RAK833 series modules are fully compliant to the 52-pin PCI Express Full-Mini Card Type F2 form factor, with top-side and bottom-side keep-out areas, with 50.95 mm nominal length, 30 mm nominal width and all the other dimensions as defined by the PCI Express Mini Card Electromechanical Specification [9] except for the card thickness (nominal value is 3.7 mm), as described in Figure 2. RAK833 series modules weight is about 9.7 g.

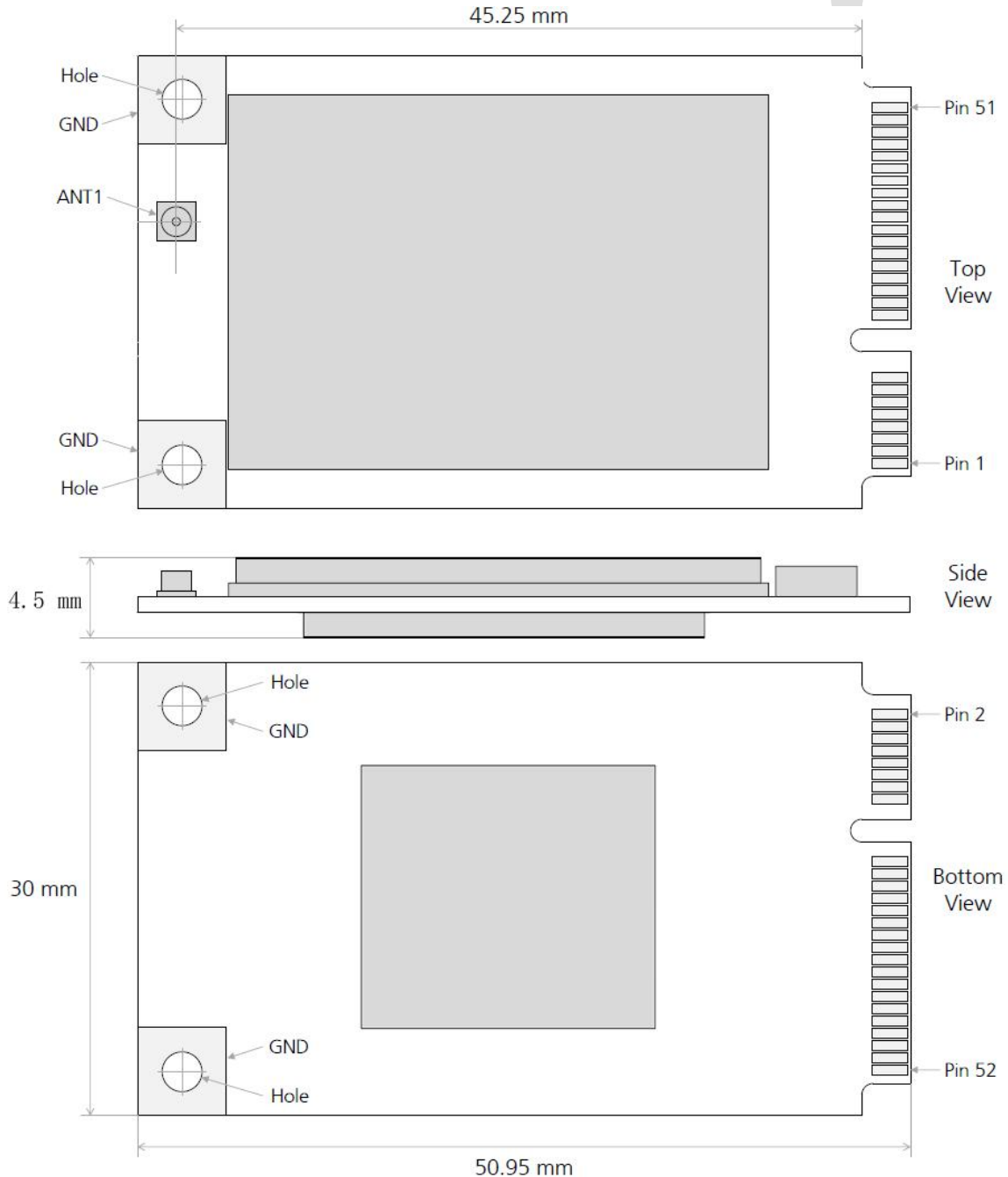

Figure 2: RAK833 series mechanical dimensions (top view, side view, bottom view)



For further details regarding mechanical specifications see the *PCI Express Mini Card Electromechanical Specification* [9].

## 6. Inner schematic

RAK833 series modules refer Semtech's reference design of SX1301, add a 4 channel SPDT to switch SPI of SX1301 to PCI edge connector or FT2232H which convert SPI to USB2.0 interface.

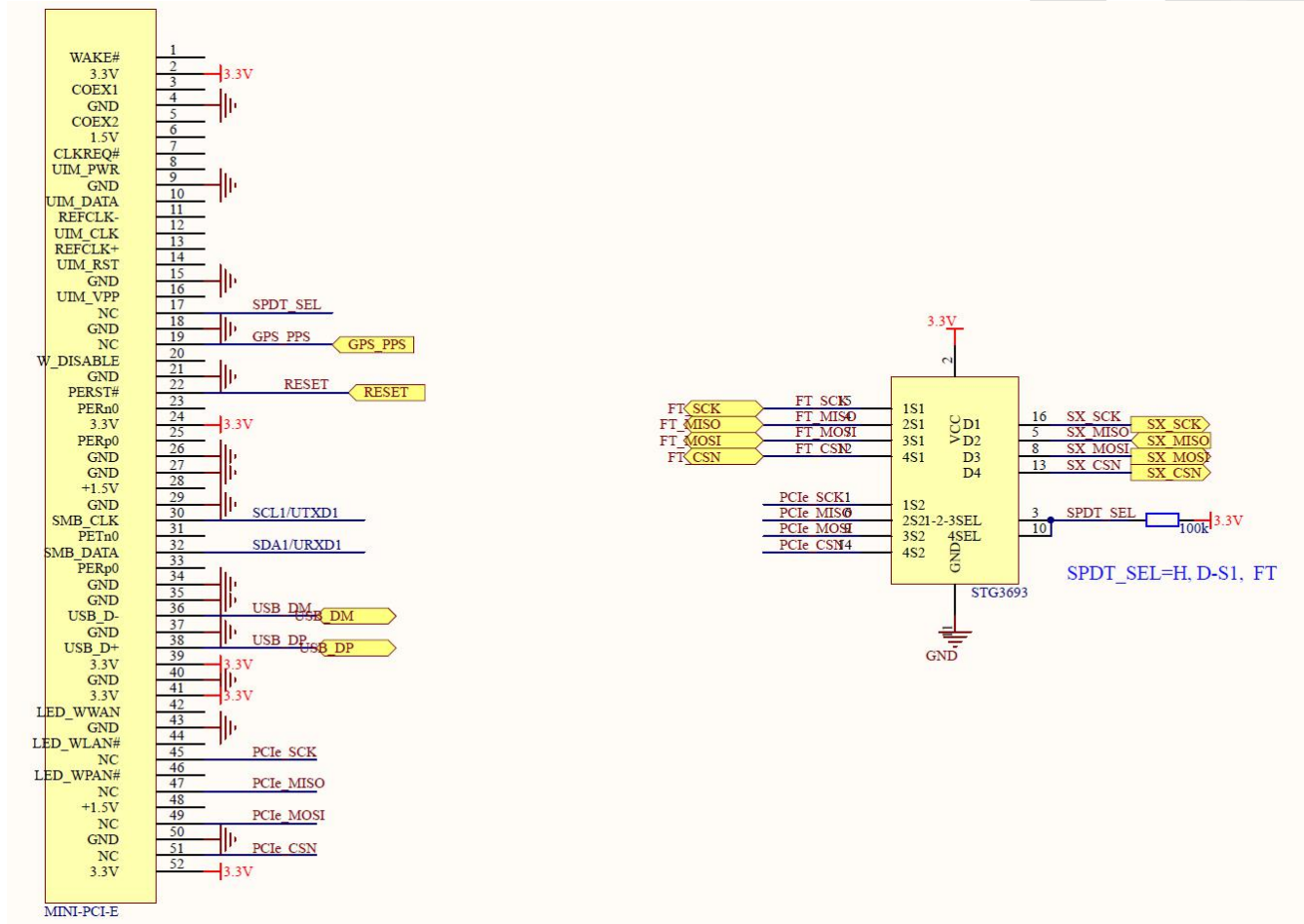

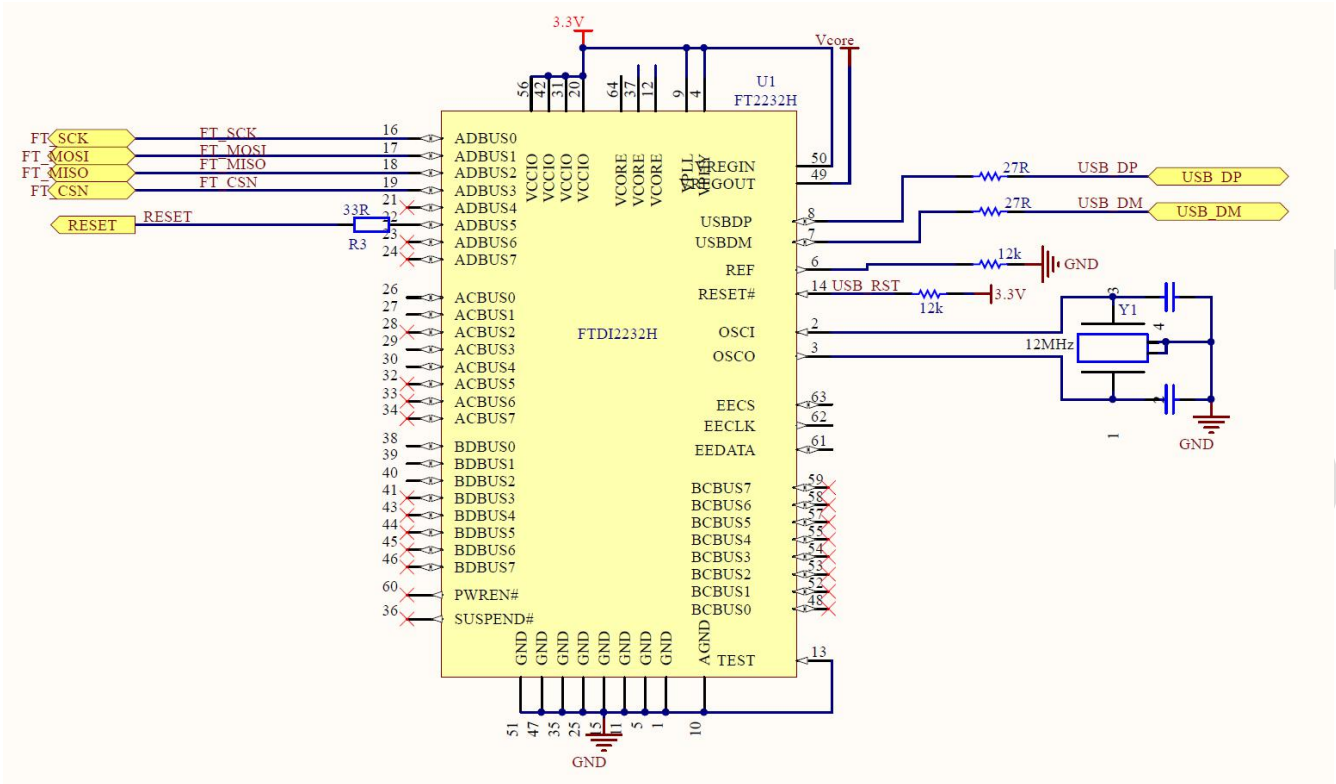

**SX1301 Part:**

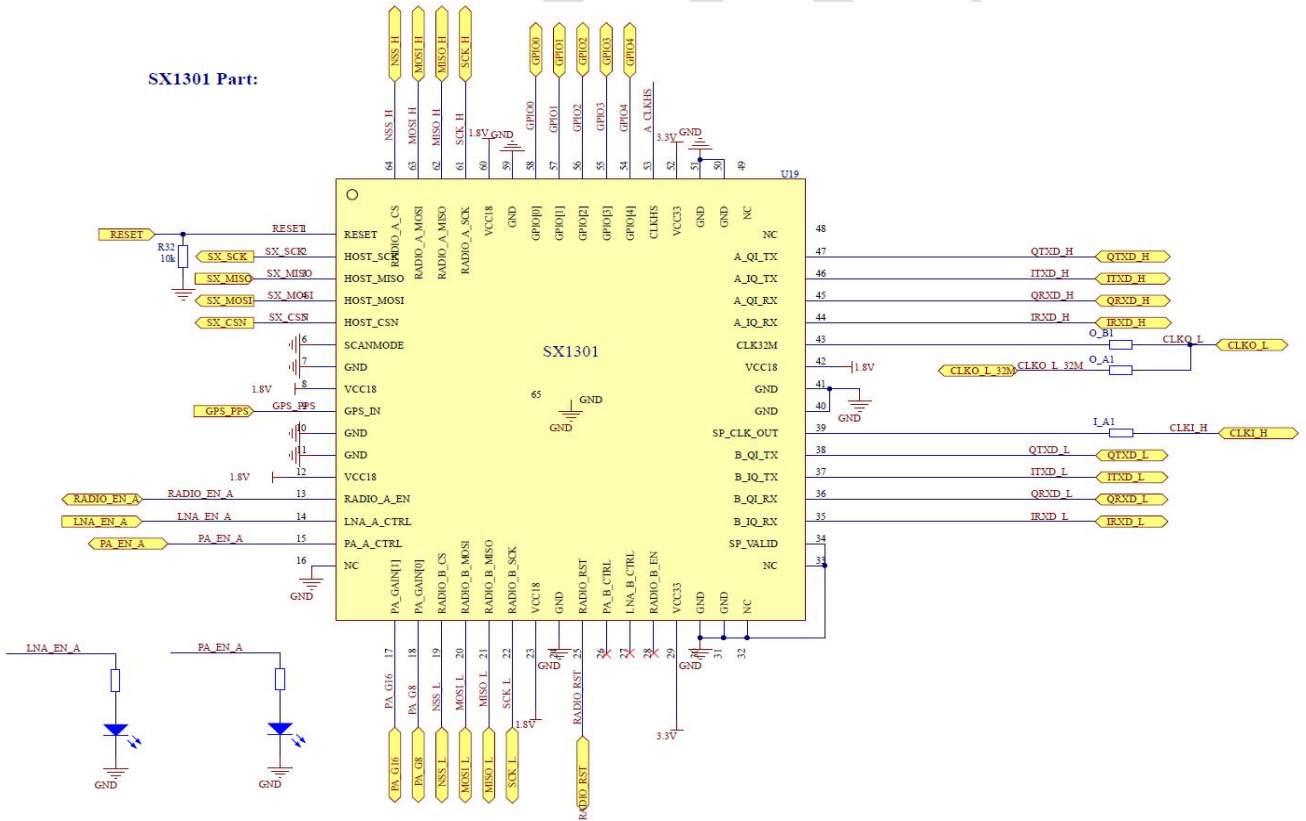

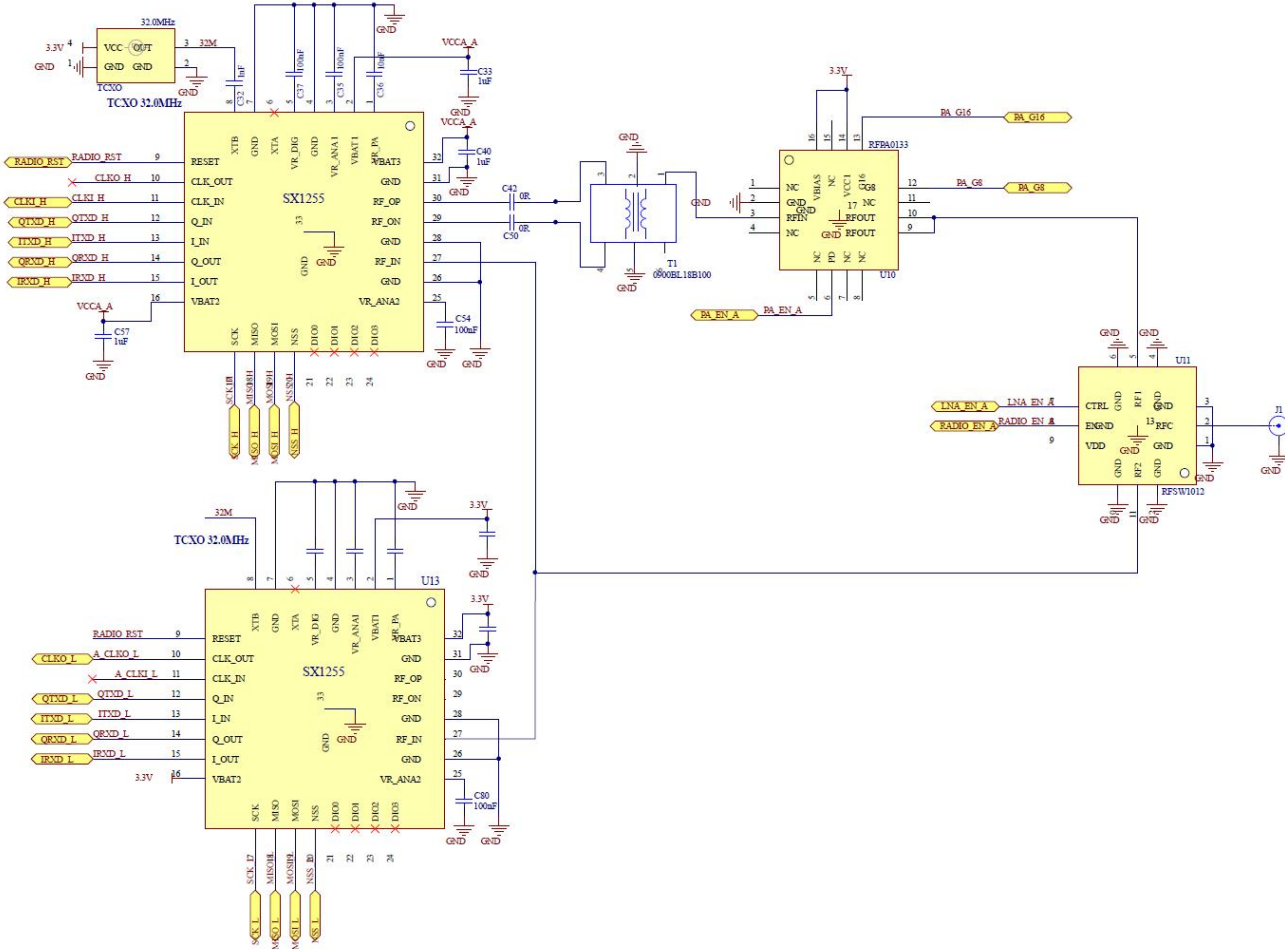

Figure 3: RAK833 series inner schematic.



For further details regarding schematic please refer "SX1301DVK\_e286v02a\_sch\_layout" from Semtech.



## 7. Reference application

Figure 4 shows the minimum application schematic of RAK833 series modules. Uses at least 3.3V/1A DC power, connect SPI interface or USB interface to the main processor. If uses SPI interface SPDT\_SEL should be tied to GND otherwise just let this pin open.

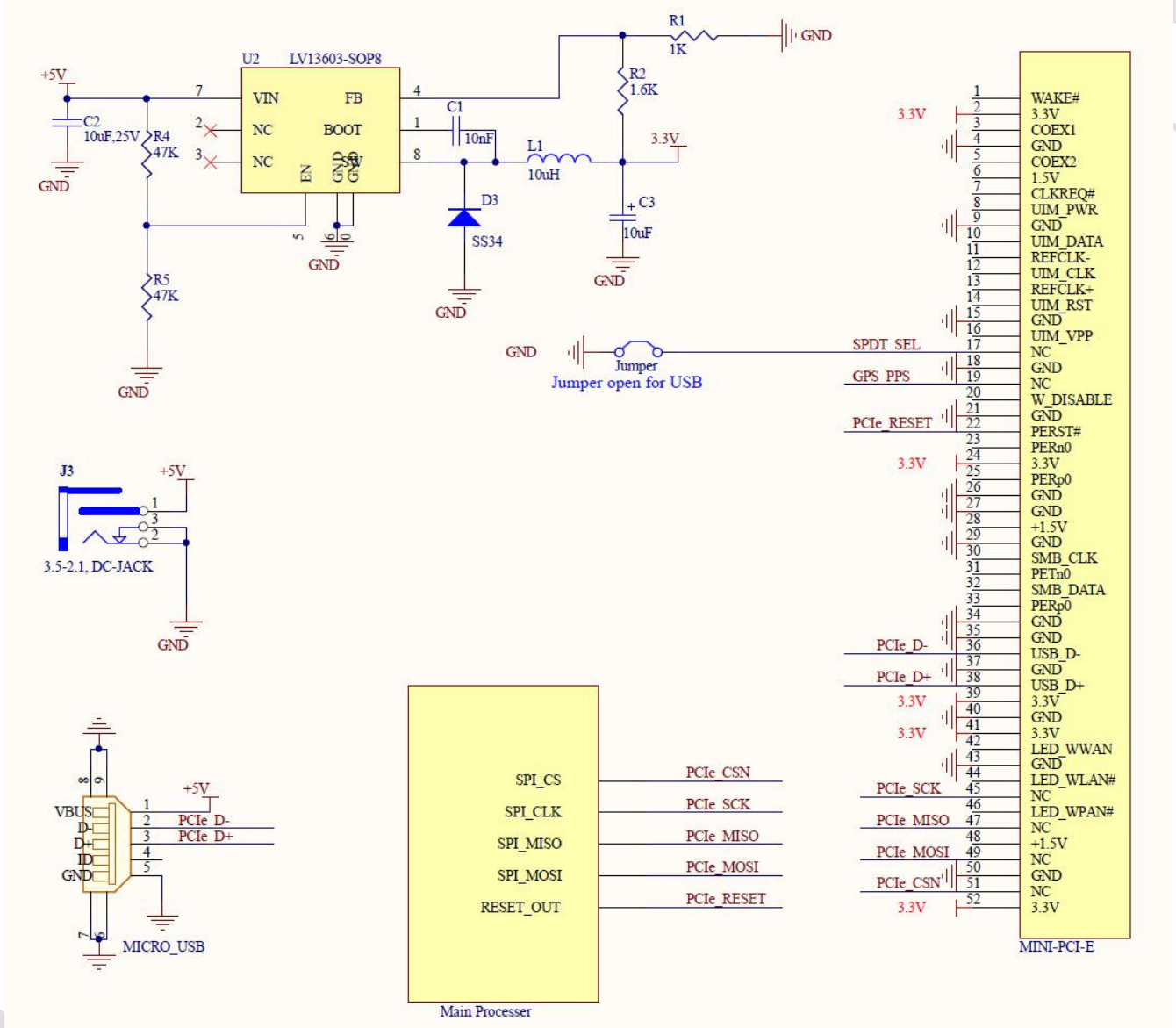

Figure 4: RAK833 series reference minimum schematic.

## 8. Contact information

### shenzhen

FAE mailbox: ken.yu@rakwireless.com

Tel : 139-1139-7114

Address: Rm. 506, Bldg. 3, Minqi Technology Park, No. 65 LiShan Road  
Xili Block, Nanshan District, Shenzhen, Guangdong Province, China

### Shenzhen

FAE mailbox: farce.chen@rakwireless.com

Tel : 0755-86108311

Fax: 0755-86152201

Address: Rm. 506, Bldg. 3, Minqi Technology Park, No. 65 LiShan Road  
Xili Block, Nanshan District, Shenzhen, Guangdong Province, China

## 9. Change Note

Version	Date	Change
V1.0	2018-01-11	Draft